

Rovanco DEF Piping

Diesel Exhaust Fluid Below Ground for Fleet Fueling/Gas Station

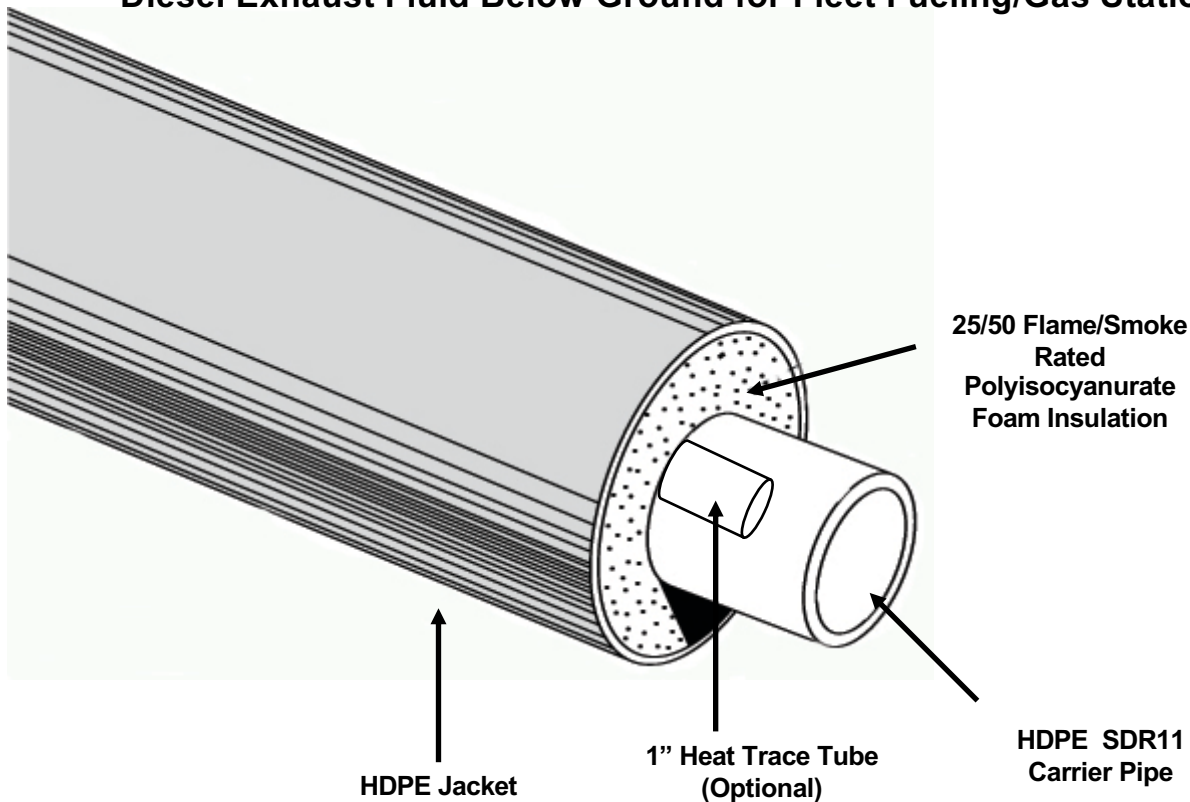

Rovanco's DEF Piping System is designed for piping systems below ground suitable for indoor and outdoor applications. High quality non-flammable polyisocyanurate foam insulation combined with a durable watertight jacket supplied 20' lengths, means an economical, high-quality system.

Rovanco's DEF Piping System is provided with a jacketing of HDPE, which can be supported from the outside with maximum supports spans. Fittings are field insulated.

The DEF System comes complete with the HDPE carrier pipe, HDPE electro-fusion fittings, joint insulation materials and jacketing to make the installation completely watertight.

To find out more about Rovanco's DEF Piping System, you can visit our factory, phone us (815) 741-6700, fax us (815) 741-4229, visit our website at www.rovanco.com or e-mail us at marketing@rovanco.com.

* For a different carrier pipe, consult factory.

SPECIFICATION FOR DEF PIPING SYSTEM – Below Ground

Carrier Pipe: HDPE

The pipe shall be made of polyethylene resin compound with a minimum cell classification by PE345434C for PE3408 materials per ASTM P3350 and D2837/. Shall contain 2% dispersed carbon black. Carrier pipe to be DR11.

Assembly is by electro-fusion for a fast, economical; and long-term performance installation.

Insulation:

Hi-Temp polyisocyanurate foam insulation has a K factor of .121, density of 2.0. closed cell content of >90%, compressive strength of 30 psi, and service temperature of 300°F. Insulation must be capable of handling intermittent temperature spikes to 350°F. Conformance with ASTM Standards D1621, 1622, 1623, 2126, 2842, 2856, and C518-91. Completely filling the annular space between the carrier pipe and jacketing. Provide written independent performance certification with submittals. Meets 25/50 Flame Smoke Rating ASTM E84. Minimum insulation thickness shall be in accordance with Table 1.

Jacket Material:

The outer casing shall be high density polyethylene (HDPE) conforming to ASTM D3350, Type III, Category 5, Class C and Grade P23/P34. With a minimum of 2% by weight of carbon black. Minimum thickness is 150 mils. No FRP overwrap or sprayed jacketing will be allowed. Minimum jacket thickness shall be in accordance with Table 1.

Nominal Pipe Size In Inches	Minimum Insulation Thickness In Included	Jacket Size In Inches	Jacket Thickness In Mils
1	1.43	4.50	150
2	1.81	6.63	150
2.5	1.56	6.63	150
3	2.25	8.00	150
4	1.75	8.00	150
6	1.68	10.00	150

* Larger pipe sizes are available upon request.

Joining Method:

Straight lengths of pipe will be joined by HDPE electro-fusion fittings.

Fitting:

All electro-fusion fittings will conform to pipe type and will be insulated and jacketed with materials supplied by the system supplier as per manufacturers' standard procedures.

End Seals:

Each length of pre-insulated pipe will be fitted with a watertight mastic end seal at jacket and pipe surfaces. All field cuts will be sealed with a field applied end seal.

Insulation of Straight Joints:

After welding and testing, all joints shall be insulated and sealed as per manufacturers' standard procedures.

Backfill: (if below ground)

Should be tamped compactly in place so as to assure a stable surface. No rock should be used in the first foot of backfill. 24 inches, top to pipe to grade, of compacted fill shall meet H-20 Highway Loading.

Manufacturer's Assistance:

Rovanco will provide a field service man on-site to properly train the installing personnel in all phases of installation, (if required).

Approved Vendors:

DEF Piping Systems by Rovanco, Joliet, Illinois. All other manufacturers wishing to bid on this project must be ISO Certified and provide the engineer with certified test data from either foam manufacturer or an independent testing agency that the product is capable of withstanding the service temperature continuously. Foam must also be rated for 25/50 Flame smoke. The manufacturer shall obtain written approval from the engineer 10 days prior to bid date.

cc #06152023

Copyright 2023 – Rovanco's products are covered by various U.S. patents. Rovanco & Insul-8 are federally registered trademarks.

Contact Rovanco® for the name of your local Representative

20535 S.E. Frontage Road • Joliet, Illinois 60431 • (815) 741-6700

Website: www.rovanco.com • E-mail: marketing@rovanco.com

This is a generic product datasheet and is not intended for submittal use.